

# Validation of an Energy Efficient MAC Protocol for Wireless Sensor Network

Sricharan Madduri and Kamran Arshad

*Mobile and Wireless Communications Research Laboratory,  
School of Engineering, University of Greenwich,  
Chatham Maritime, Chatham ME4 4TB, United Kingdom*

*E-mail address: k.arshad@greenwich.ac.uk*

*Received 17 April 2013, Revised 14 Aug. 2013, Accepted 30 Aug. 2013, Published 1 Sep. 2013*

**Abstract:** Energy-efficiency is generally regarded as one of the fundamental challenges for wireless sensor networks and the radio part is a major contributor to overall energy consumption of a sensor node. A Radio Triggered Sensor MAC (RTM) protocol was introduced in the literature, which could harvest the overall energy consumption in WSNs. In this article, we propose, design and develop hardware which we refer as Passive Radio Sensor (PRS) and use is to study the RTM protocol in WSNs. A general radio transceiver, typically used in WSN, consumes a significant amount of energy when periodically listening to data messages. Our proposed transceiver hardware, PRS, powered by the incoming radio signals themselves and hence significantly reduces node energy consumption that is wasted in radio communications. The PRS circuit is independent of any other components on the node.

**Keywords:** ZigBee, Radio-Triggering.

## I. INTRODUCTION

Wireless Sensor Network (WSN) is the combination of a large number of sensor nodes which may be densely deployed in a given area to sense a physical or biological phenomenon and then process the gathered or sensed information and, send it back to the user (Anastasi et al., 2009; García-Hernández et al., 2007; Yick et al., 2008). A typical node, in a WSN, has memory to store the data, processing unit such as microcontrollers and transceivers to transmit and receive the data. Each WSN node is generally powered by external power sources such as batteries (Alshareeda, 2013; Ihbeel and Sigiuk, 2012). As the coverage area of each sensor node is limited, normally several sensor nodes are deployed to cover a certain geographical area. Medium Access Control (MAC) protocols are used in WSNs to coordinate data communication among sensor nodes (Alshareeda, 2013). A large number of MAC protocols for WSN are available in the literature; for a detailed review the reader may refer to (Madduri and Arshad, 2013; Yi et al., 2011). Due to the rigorous resource limitations, sensor network applications make use of the hardware peripherals in a sensible manner. A common technique that attempts to

save energy by using control mechanisms that turns off the hardware resources when not in use. Sensor nodes are generally powered by battery, therefore the available battery power is the most precious resource in a WSN and directly affects the lifetime of the network. In typical WSN applications, RF communications require the highest energy consumption budget (Anastasi et al., 2009; Ansari et al., 2009; Le-Huy and Roy, 2008). Since there is less data traffic in WSNs, most of the energy is wasted in idle listening by a radio, i.e., waiting in expectancy for a data packet. Radio duty cycling is an accepted solution in which, the radio is turned on and off periodically for a certain time limit, specific to each MAC protocol (Akyildiz et al., 2007; Demirkol et al., 2006; Ye et al., 2004). However, there exists a trade-off between energy consumption and the corresponding time delay for data communication in duty cycling MAC protocols. As a result lower duty cycle result in higher energy savings, but at the same time there is an increased latency for data communication.

In (Ansari et al., 2009), a radio triggered MAC (RTM) protocol was proposed and authors demonstrated the efficacy of the protocol by computer simulations. In this article, we further analysed the RTM protocol and

proposed the design of a radio triggered wake-up hardware attached to a sensor node that allows it to keep its on-board radio element completely switched off until there are data packets for communications (El-Medany, 2009). Our proposed circuit (i.e. PRS) is easy to implement on commercially available sensor nodes. We also conducted a series of experiments at the Mobile and Wireless Communications Laboratory (MWCL) at the University of Greenwich and demonstrated the functionality of our hardware. We repeatedly sent the data and observed the energy consumption of the sensor node when it was in a sleep state and when it was in a wake-up state.

Although a number of MAC protocols for WSN are available, however, in most of the state-of-the-art solutions the radio circuitry is always in an idle listening state that consumes energy (Anastasi et al., 2009; Le-Huy and Roy, 2010; Yi et al., 2011). In our proposed solution idle listening can be avoided by keeping the on board radio off, to avoid idle listening and micro-controller trigger the sensor to turn it on. Therefore our solution is achieved by combining the ideas together i.e. the radio triggered wake-up techniques, MAC procedures for reliable data communication and highly energy efficient operation.

The article is organized as follows: In section II hardware requirements and setup, section III explains about our proposed scheme, section IV explains the deployments of our proposed scheme, section V presents experimental results and discussion of experimental results and finally section VI concludes this article.

## II. HARDWARE REQUIREMENT AND SETUP

We used three ZigBee CC2500 base modules and designed two Printed Circuit Boards (PCB) in our experiments. In the ZigBee base module, a RS-232 male connector was connected to the RS-232 female port to attain serial communication. All the components were connected to each other as shown in Fig. 1. There were various concerns that were paid attention to during the setup:

- To ensure that the CC2500 was properly set up in the ZigBee Base module.
- To measure and verify that PIC18F4520 received at least 5V.

A star topology was used and one CC2500 ZigBee module was used as the coordinator, which was directly connected to a Personal Computer (PC) for transmission and reception of messages through the network. Node-1 was used as an end device (i.e. receiver) it was able to communicate with the coordinator as shown in Fig. 1.

The receiving end consists of a ZigBee sensor node, which acts as a passive radio sensor (Blumenthal et al., 2007; Watthanawisuth et al., 2009; Wheeler, 2007). When the ZigBee radio is turned off it consumes negligible amount of energy that helps in waking-up the node when there is data to communicate. In our circuit, micro-controller acted as a sleeping node and performed

the sleep and wake-up operations when needed. Hence, the full module (i.e. micro-controller with ZigBee) is referred as PRS. The micro-controller will always be in sleep mode except when there is data to display.

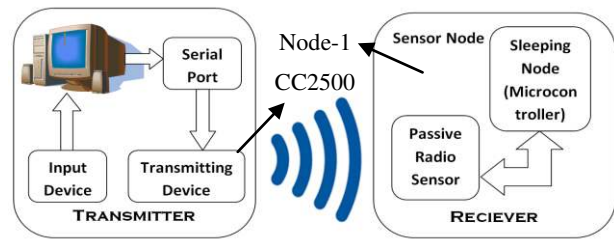

Fig. 1. Block diagram of transmitter and receiver

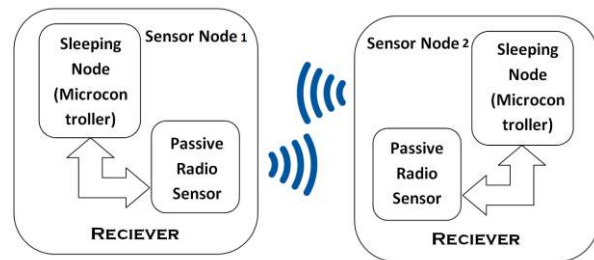

Fig. 2. Block diagram of neighbor node communication

Fig. 2 shows the data communicating between the neighboring sensor nodes as the distance of each sensor node is restricted. Here either of the nodes receives the data from the administrator node through the coordinator. The data received can be transmitted to the neighboring node with the help of a passive radio circuit. As explained later in section V, node 1 receives the data from the administrator and a wake up signal is sent to the neighbor node-2 by triggering and by doing this sensor node-2 wakes up to receive the message from node-1. After the data communication takes place both the nodes enter into the sleep state to save energy.

## III. OUR PROPOSED SOLUTION

In this article we implemented and verified experimentally a new MAC scheme, Radio Triggered scheme, in which the RF part of the circuit board is turned off and wakes up only when it receives message; flow chart of algorithm is given in Fig. 3. The energy managed sleep mode in the PIC18F4520 is identical to the legacy sleep mode offered in other PIC micro-controller devices. Entering the sleep mode from any other mode does not require a clock switch. This is due to the reason that no clock is needed once the controller has entered in sleep state. If the Timer1 oscillator (see Fig. 4) is enabled, it continues to run. The code was written according to the algorithm illustrated in Fig. 3. To build the code into the PIC18F4520, MPLAB was used as an Integrated Development Environment (IDE).

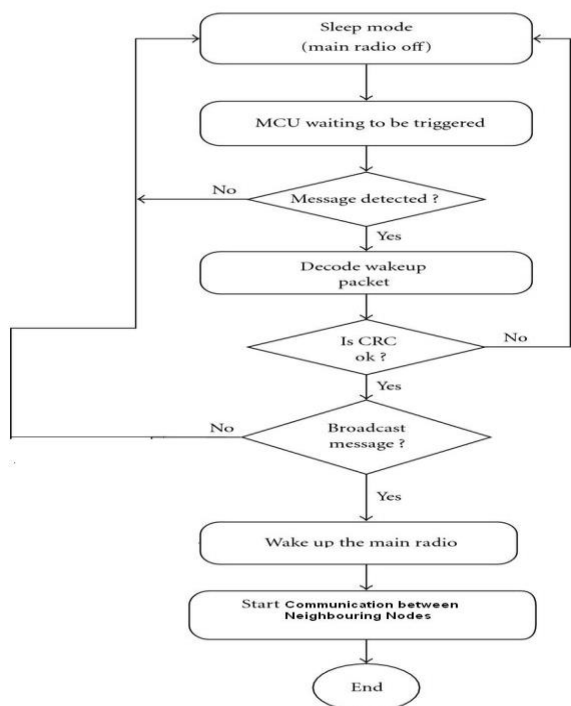

Fig. 3. Flow chart of sleep and wake-up mechanism

#### IV. DEPLOYMENT OF PROPOSED SCHEME

In this article, the transmitting device consists of the ZigBee modules and MAX-232 IC, which can convert the data into the TTL level signals which is acceptable by the ZigBee for communication. The receiver end consists of the ZigBee modules which acts as receiver and also acts as a passive radio sensor. When the RF part of the radio is turned off it consumes negligible energy and it helps in waking-up the node when there is a data to communicate. Our sensor module (i.e. Micro-controller and ZigBee) are always in sleeping mode except when there is data available. Micro-controller (MC) on each node senses the signals in a particular time slot from ZigBee transmitter, MC will wake up and display the data in the particular sensor node. After that, the sensor node can transmit the same data to the neighbouring sensor node (e.g. communication between two sensor nodes) which is depicted in Fig. 6. Once the communication session is finished the sensor nodes go to sleep mode.

In this article, ZigBee modules are used as a transmitter in the transmitting unit and as a passive radio sensor in the receiving unit. It is easier and secured if the number of users using this ZigBee within the network forms in to clusters and access through a common port of the ZigBee to reduce the energy consumption and can monitor the rate of energy consumed easily.

To communicate among sensor nodes a serial mode of communication is used. Hyper terminal is the communication tool used as it is ease to operate and easily available in built tool for all the operating systems. In our experiments, transmitter device was the computer

and receiver was a ZigBee sensor node. In the sensor nodes MC acts as a master controlling sleep and wake-up sessions accordingly.

#### A. Transmitting unit

The complete circuit was built as a single small board to transmit the data as shown in the Fig. 4. The main components used in our circuit are ZigBee CC2500 transceiver, MAX232, power supply circuit and a serial port. Voltage levels used at the control station (i.e. Computer) are RS-232 and these logic levels are needed to be converted to TTL levels (i.e. 0 and 5V) as ZigBee operates on TTL logic levels. MAX232 acts as a route driver and it changes RS-232 voltage levels to TTL logic levels. Therefore it acts as an interface between computer and ZigBee. ZigBee is a transceiver, it can transmit as well it can receive the data or signal, and here it is used as a transmitter.

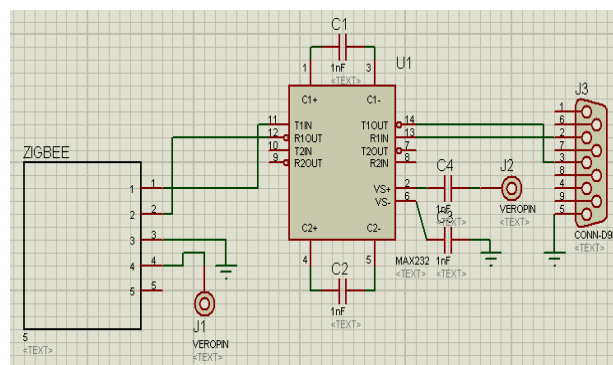

Fig. 4. Transmitter circuit diagram

The transmit pin (TX) and receiver pin (RX) of ZigBee is connected to T1IN and R1OUT pins of MAX232 and also T1OUT and R1IN pins of MAX232 were connected to serial port (see Fig. 4), serial port was connected to computer through serial to com port connector hardware. So whenever some data is to be transmitted one can use computer keyboard as input device, with the use of hyper terminal tool provided by windows communication can be accessed.

#### B. Receiving Unit

The receiver unit circuit designed is on a single board as shown in Fig. 5. The major components in the receiver circuit are the Microcontroller, ZigBee CC2500, LCD, buffer and power supply. Here in the circuit ZigBee was used as a Passive radio sensor and also as a receiver device and micro controller works as a sleeping node. The TX and RX pins of ZigBee are connected to the TX and RX pins of PIC18F4520 micro-controller. A 20MHz oscillator is connected to micro-controller's CLK pins to produce the trigger. Port C on micro-controller is interfaced with LCD and port E enable pin RE1 to ULN2803A buffer to enable the LCD. The VCC and GND pins of the circuit components are connected to the power supply. When the passive radio sensor senses the particular data transmitted it energizes itself and wakes up

the micro-controller that display data on the LCD. Once the ZigBee receives data its radio turned on and send a wake up signal to the MC. Once the received data is decoded and displayed on the LCD, the sensor node gets back to its default sleep state. If the data needs to communicate with its neighbor sensor node then the RF part is turned on and a trigger is given to wake up the neighbor node.

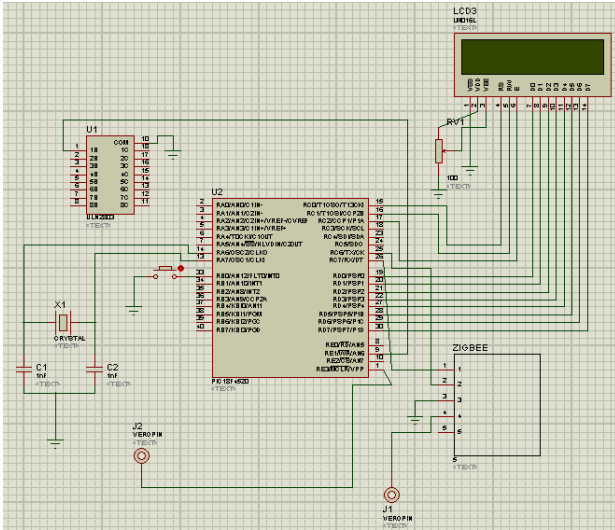

Fig. 5. Receiver circuit diagram

C. ZigBee CC2500

The ZigBee used in our experiments was ZigBee CC2500. It is low cost and low power device. In the receiver circuitry, ZigBee is used as a passive radio sensor and also as a receiver, which has the capability to turn off the radio when not in use and wake up when there was a message to communicate. In the receiver unit ZigBee along with the micro-controller forms as a sensor node.

D. MAX 232

MAX232 is an integrated circuit, which converts the voltage, which is above or below the operating range (i.e., 0V to 5V). It is connected to the serial port of RS232 to convert the voltage to the TTL logic voltage level, which is supported operating range of micro-controller.

V. EXPERIMENTAL RESULTS AND DISCUSSION

The aim of our experiments was to practically attain highly energy efficient data communication in WSN with low latency. For this we designed transceiver circuits and observe the power levels when nodes were in sleep and wake up states. To communicate data through the ZigBee devices a Hyper terminal serial communication tool was used as shown in Fig. 6.

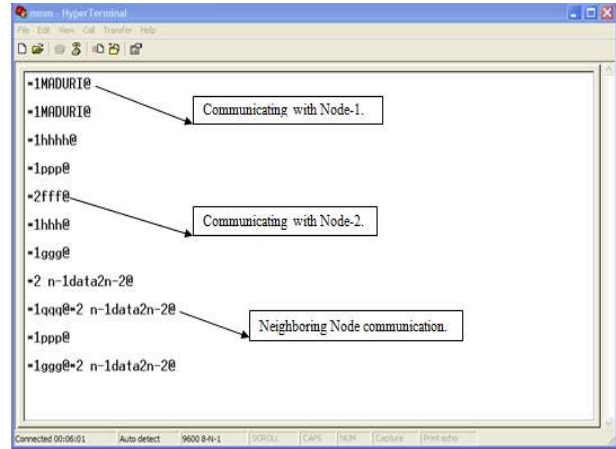

Fig. 6. Hyper terminal window

Fig. 6 shows the Hyper terminal window in which the data were transmitted to the ZigBee Coordinator through RS232 serial communication interface device. Here \*1 on the screen indicates that it was communicating with node-1 and similarly with node-2.

A. Node-1 sleep state

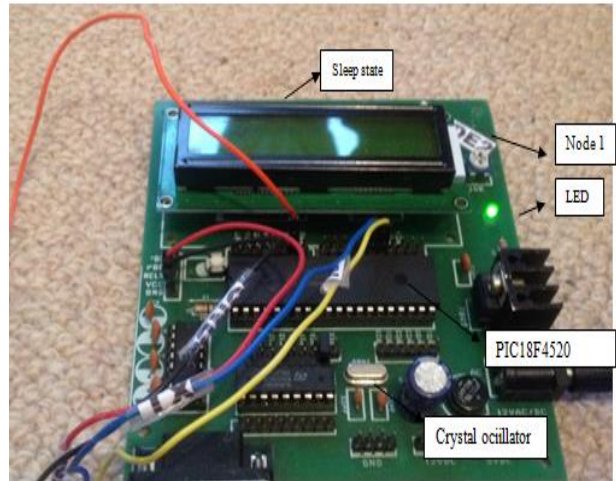

Fig. 7. Node-1 state when the power was ON

Fig. 7 shows when there was no communication session initiated and the sensor node was in a sleep state even when the power was given to the circuit board (see Fig. 7, green LED glow). The MC acts as a node and the ZigBee act as a special hardware component and both microcontroller and ZigBee are together known as sensor node.

B. Node-1 wakes up status

In Fig. 8, there was a message sent from the administrator to the sensor node-1. Therefore the ZigBee and additional hardware circuit receives the data and a wake up signal was sent and the MC which wakes up, receives data and display on the LCD. After the data transmission was completed the sensor nodes get back to the sleep state to attain energy efficiency. Unique addressing was given to the two different nodes.



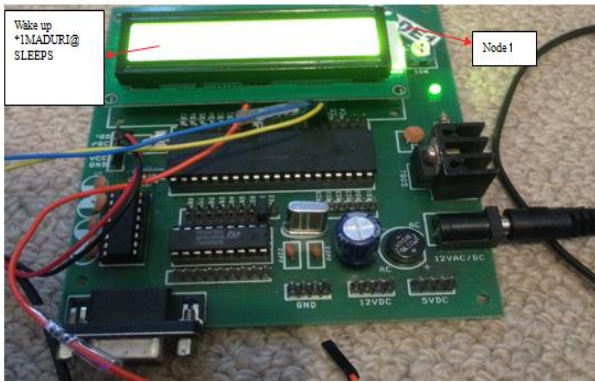

Fig. 8. Node-1 receives message.

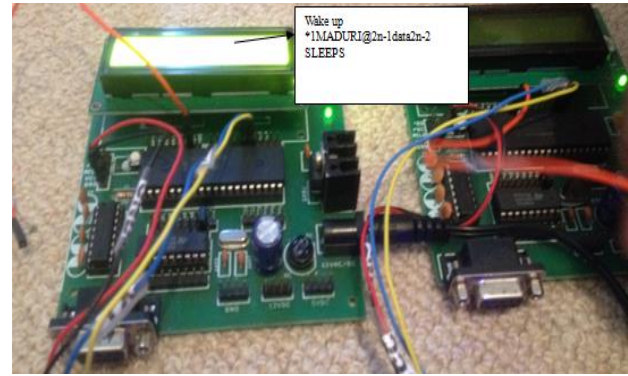

Fig. 10. Communication between nodes

**B. Triggering Results of Node-1**

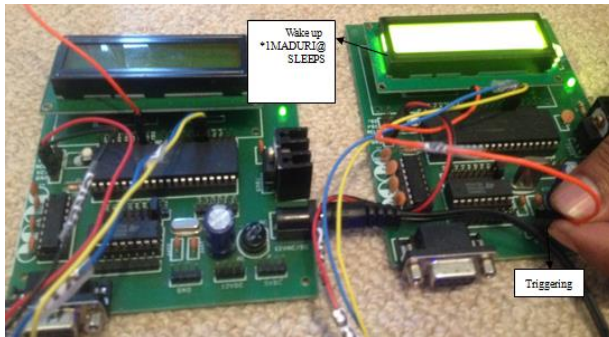

Fig. 9. Trigger Node-2 by Node-1

Fig. 9 shows communication between the neighboring nodes. Once the message received to the sensor node-1 from the coordinator, that message is communicated to the neighboring sensor node-2. The radio on the sensor node-1 is turned on and a trigger is given to the neighboring sensor node-2. After sending message to the neighboring node the sensor node-1 goes back to the sleep mode to gain energy efficiency data communication and the message was displayed on the LCD. RB0 pin on the micro controller was given to the ground.

**C. Neighboring node communication results**

Fig. 10 shows that once the trigger was given by the sensor node-1 to the sensor node-2 then sensor node-1 goes into sleep mode and the wake up signal was sent to the MC of sensor node-2. MC of sensor node-2 wakes up and receives data sent by sensor node-1 and that message was displayed on LCD. After displaying the data, sensor node-2 goes back to sleep mode to save energy. Unique addressing was given to the two different nodes and \*1 was assigned to sensor node-1 to start, @ to end and \*2 was assigned to sensor node-2, @ to end the data.

Fig. 11 shows that the current flow in each sensor node in sleep and wake up states. Sensor node in sleep state consumes 0.07 amperes while in wake up state it consumes 0.08 amperes of current. As voltage was kept constant at 5V, the power was 0.35 watts when it was in sleep state and 0.40 watts when it was in wake up state, as shown in Fig. 12.

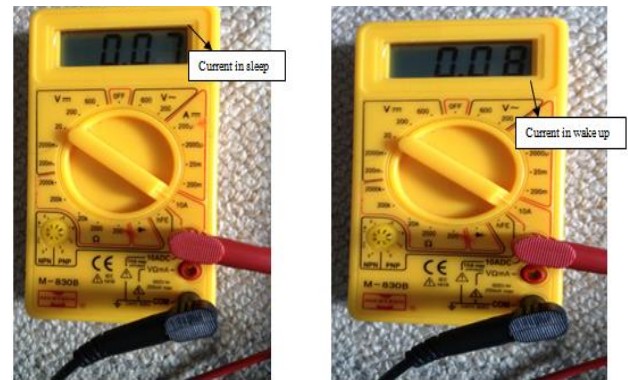

Fig. 11. Current in sleep and wake-up states

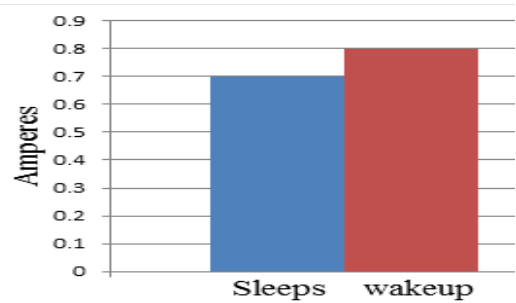

Fig. 12. Current consumption in sleep and wake-up state

**VI. CONCLUSIONS**

In this article, we have proposed the transceiver circuit of a new energy efficient MAC protocol (i.e. RTM) which has advantage of low latency and high energy efficiency. The RTM uses a passive radio sensor which wakes up the node from the sleep state whenever there is communication required. In passive radio sensor, a node remains in sleep mode for most of the time and wakes up instantly when triggered by ZigBee. The experimental results demonstrated that protocol is energy efficient and also has very low latency.

**ACKNOWLEDGMENT**

The research leading to these results was derived from the University of Greenwich Research & Enterprise Investment Programme grant under agreement number RAE-ENG-04/12.

## REFERENCES

- [1] AKYILDIZ, I.F., MELODIA, T., CHOWDURY, K.R., 2007. WIRELESS MULTIMEDIA SENSOR NETWORKS: A SURVEY. WIRELESS COMMUNICATIONS, IEEE 14, 32-39.
- [2] ALSHAREEDA, S.Y., 2013. PRM MITIGATION SCHEME FOR THE NODES FAILURE EFFECT IN THE WSNs CGD PROTOCOL. INT. J. COM. DIG. SYS 2, 29-37.
- [3] ANASTASI, G., CONTI, M., DI FRANCESCO, M., PASSARELLA, A., 2009. ENERGY CONSERVATION IN WIRELESS SENSOR NETWORKS: A SURVEY. AD HOC NETWORKS 7, 537-568.
- [4] ANSARI, J., PANKIN, D., MÄHÖNEN, P., 2009. RADIO-TRIGGERED WAKE-UPS WITH ADDRESSING CAPABILITIES FOR EXTREMELY LOW POWER SENSOR NETWORK APPLICATIONS. INTERNATIONAL JOURNAL OF WIRELESS INFORMATION NETWORKS 16, 118-130.
- [5] BLUMENTHAL, J., GROSSMANN, R., GOLATOWSKI, F., TIMMERMANN, D., 2007. WEIGHTED CENTROID LOCALIZATION IN ZIGBEE-BASED SENSOR NETWORKS, INTELLIGENT SIGNAL PROCESSING, 2007. WISP 2007. IEEE INTERNATIONAL SYMPOSIUM ON. IEEE, PP. 1-6.
- [6] DEMIRKOL, I., ERSOY, C., ALAGOZ, F., 2006. MAC PROTOCOLS FOR WIRELESS SENSOR NETWORKS: A SURVEY. COMMUNICATIONS MAGAZINE, IEEE 44, 115-121.
- [7] EL-MEDANY, W., 2009. FPGA-BASED MIMO SYSTEM FOR WIRELESS SENSOR NETWORK, SYSTEM OF SYSTEMS ENGINEERING, 2009. SoSE 2009. IEEE INTERNATIONAL CONFERENCE ON. IEEE, PP. 1-5.
- [8] GARCÍA-HERNÁNDEZ, C.F., IBARGUENGOYTIA-GONZALEZ, P.H., GARCÍA-HERNÁNDEZ, J., PÉREZ-DÍAZ, J.A., 2007. WIRELESS SENSOR NETWORKS AND APPLICATIONS: A SURVEY. IJCSNS INTERNATIONAL JOURNAL OF COMPUTER SCIENCE AND NETWORK SECURITY 7, 264-273.
- [9] IHBEEL, A.A.-M., SIGIUK, H.I., 2012. PERFORMANCE EVALUATION OF DYNAMIC SOURCE ROUTING PROTOCOL (DSR) ON WSN. INT. J. COM. DIG. SYS 1, 19-24.
- [10] LE-HUY, P., ROY, S., 2008. LOW-POWER 2.4 GHZ WAKE-UP RADIO FOR WIRELESS SENSOR NETWORKS, NETWORKING AND COMMUNICATIONS, 2008. WIMOB'08. IEEE INTERNATIONAL CONFERENCE ON WIRELESS AND MOBILE COMPUTING. IEEE, PP. 13-18.
- [11] LE-HUY, P., ROY, S., 2010. LOW-POWER WAKE-UP RADIO FOR WIRELESS SENSOR NETWORKS. MOBILE NETWORKS AND APPLICATIONS 15, 226-236.
- [12] MADDURI, S., ARSHAD, K., 2013. EXPERIMENTAL VALIDATION OF AN ENERGY EFFICIENT MAC PROTOCOL FOR WIRELESS SENSOR NETWORK, COMMUNICATIONS, SIGNAL PROCESSING, AND THEIR APPLICATIONS (ICCSPA), 2013 1ST INTERNATIONAL CONFERENCE ON. IEEE, PP. 1-5.
- [13] WATTHANAWISUTH, N., TUANTRANONT, A., KERDCHAROEN, T., 2009. MICROCLIMATE REAL-TIME MONITORING BASED ON ZIGBEE SENSOR NETWORK, SENSORS, 2009 IEEE. IEEE, PP. 1814-1818.
- [14] WHEELER, A., 2007. COMMERCIAL APPLICATIONS OF WIRELESS SENSOR NETWORKS USING ZIGBEE. COMMUNICATIONS MAGAZINE, IEEE 45, 70-77.
- [15] YE, W., HEIDEMANN, J., ESTRIN, D., 2004. MEDIUM ACCESS CONTROL WITH COORDINATED ADAPTIVE SLEEPING FOR WIRELESS SENSOR NETWORKS. NETWORKING, IEEE/ACM TRANSACTIONS ON 12, 493-506.
- [16] YI, X.-S., JIANG, P.-J., WANG, X.-W., ZHANG, S.-C., 2011. SURVEY OF ENERGY-SAVING PROTOCOLS IN WIRELESS SENSOR NETWORKS, ROBOT, VISION AND SIGNAL PROCESSING (RVSP), 2011 FIRST INTERNATIONAL CONFERENCE ON. IEEE, PP. 208-211.
- [17] YICK, J., MUKHERJEE, B., GHOSAL, D., 2008. WIRELESS SENSOR NETWORK SURVEY. COMPUTER NETWORKS 52, 2292-2330.



**Sricharan Madduri** holds MSc degree in Wireless and Mobile Communications from University of Greenwich, London in 2012. He is currently working in Blues Innovations company. Sricharan Madduri graduated from Sathyabama University, India.



**Kamran Arshad** received his BEng, MSc and PhD in Electrical Engineering with Distinction in 2000, 2003 and 2007 and currently working as a Senior Lecturer at University of Greenwich. Dr Arshad research interests are in general area of cognitive radio, LTE-Advanced and in general area of future networks. He is an author of a book titled Radio wave propagation modelling using finite element method (Lambert Publishing, 2010) and author of over 80 technical papers published in peer-reviewed international Journals and conferences. He received 03 best paper awards and chaired 03 technical sessions in leading international conferences. He served more than 30 conferences as a Technical Programme Committee (TPC) member and editor of International Journal of Artificial Intelligence. Dr Arshad was officially invited to become a panellist in IEEE PIMRC 2011 workshop on cognitive radio, Toronto, Canada (September 2011). He was also invited as a speaker in International Software Radio Symposium held in London, UK (June 2012).